



# Boom Barrier Gate



## Features :

- The operating speed of Barrier is 1.5 Sec - 5 Sec (adjustable according to different boom arm length)
- Reversible boom arm direction, compact and straightforward transmission mechanism, easy to install on-site
- Manual raising of the gate arm; anti-smashing
- The body of Barrier is made of 1.5mm Powder coated Mild Steel plate and tempered glass
- The gate arm will move to the original position when it detected something blocked it
- 24V backup battery, ensuring normal operation when power is unexpectedly disconnected (Optional)

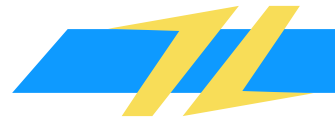

## Dimension :

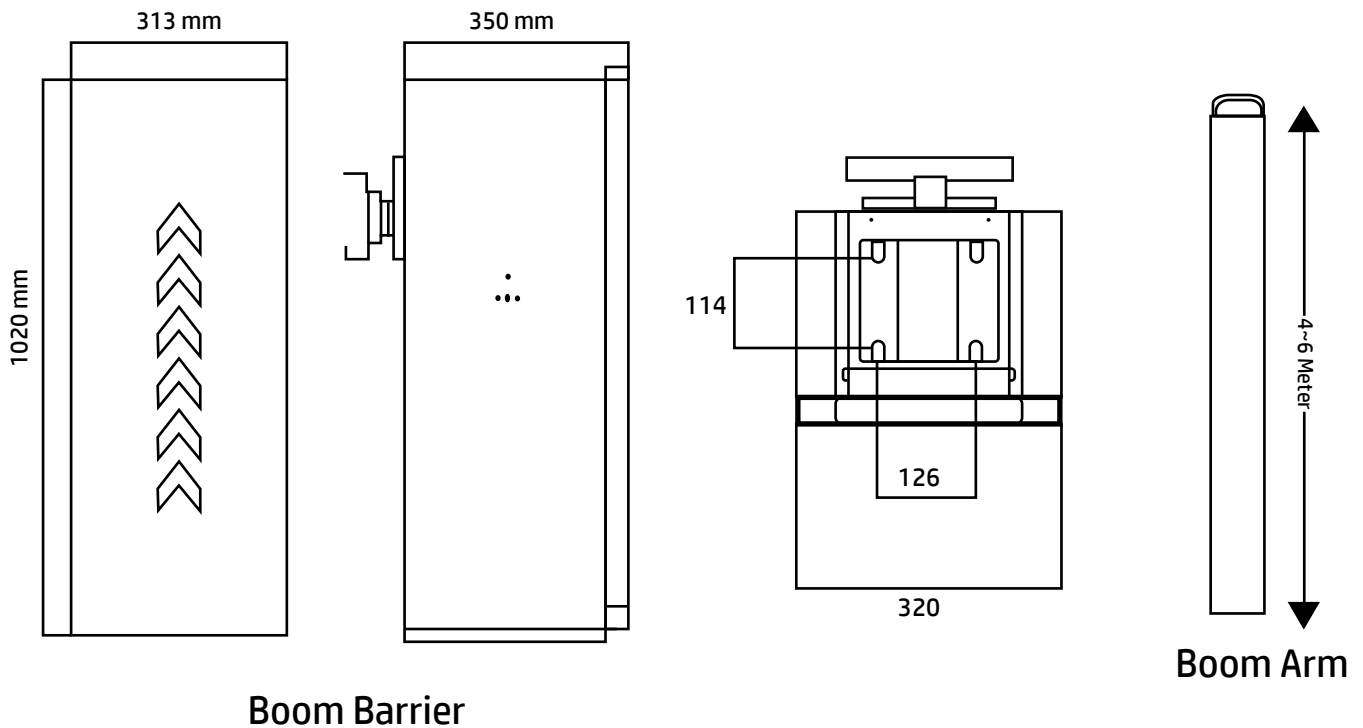

## Specification:

Motor	:	DC24V Brushless Industrial Motor
Power Consumption	:	150W
Boom Arm	:	6 Meter Telescopic
Life Cycle	:	9 Million Times
Arm Speed	:	1.8S-5S (can Set)
Operating Voltage	:	220V±10% 50~60Hz
IP Rating	:	IP54
Communication	:	RS485/Dry Contact
Operation Condition	:	-30°C~70°C
Operating Humidity	:	20%~95% No Condensation
Housing Thickness	:	1.5mm
Body Material	:	Carbon Steel Paint+Baking finish + Tempered Glass
Dimensions	:	350*313*1020mm
Railing size	:	folding stick≥5m, rack staks≥5m, straightbar≥6m
Net Weight	:	60 Kg



## Directions :

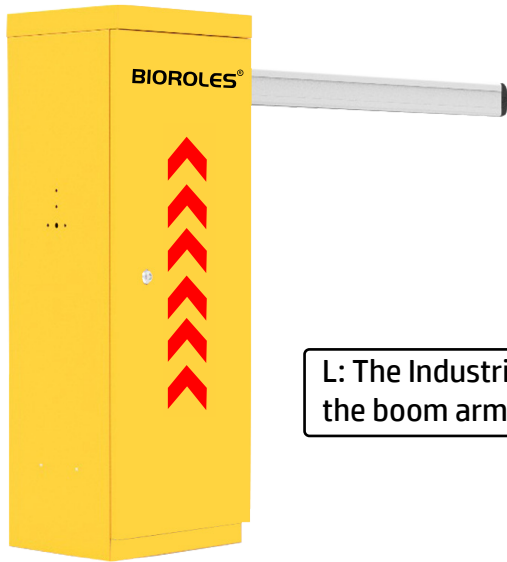

L: The Industrial on the left,  
the boom arm on the right



R: The Industrial on the right,  
the boom arm on the left

## Related Products :

